

APPLICATION NOTE

QBAR® ICs provide a 3-terminal semiconductor switch that functions as:

- a solid-state normally-closed switch
- a non-inverting digital transistor
- a solid-state replacement for a normally-closed, non-isolating relay.

QBAR® ICs do not require a separate power supply lead. This makes possible:

- simplified control wiring
- replacement of normally-closed D.C. relays with highly reliable solid-state devices
- improved fail-safe performance in the event of lost control power, severed or shorted control wires.

QBAR SWITCH SYMBOL

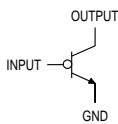

FUNCTIONAL SCHEMATIC

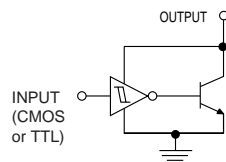

FUNCTION TABLE

INPUT	SWITCH STATE (OUTPUT-TO-GND)
HI	OFF
LO	ON
OPEN	ON

QB104M3G



SOT-23 (TO-236)
20 Volts
175 mA

Pb-free RoHS

QB104Z

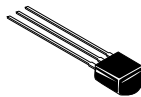

TO-92
20 Volts
175 mA

Low cost

QB210T

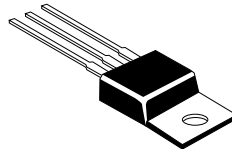

TO-220
20 Volts
3 Amps

Grounded copper tab

For other package options and for QB312 information, contact BitParts, Inc.

POWER SUPPLY EFFICIENCY BOOST

Increase your power supply efficiency by using a QBAR switch to lower the parasitic current drain through the bleeder resistor during normal supply operation. A QBAR switch, OFF during normal operation, is turned ON at supply turn-off and stays ON when all voltages fall to zero.

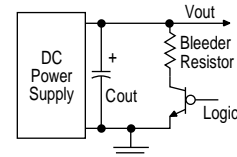

INDICATE STATUS SIMPLY AND RELIABLY

HI on the status line drives GO indicator through a power MOSFET or Darlington. LO on a status line drives the NO GO indicator through the QBAR switch; a break or a short to ground in status line will also drive the NO GO indicator. Requires only the indicator/display supply – no local logic supply.

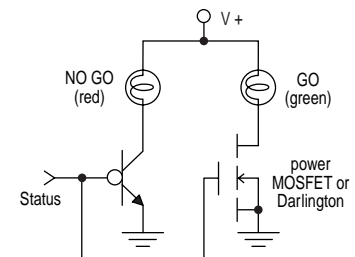

QBAR SWITCH IN PARALLEL WITH FRAGILE OR TRIGGER DEVICE

A QBAR switch protects the load from being driven by false signals when all status indicators are not OK. Damage to fragile loads such as laser diodes, or erroneous firing of detonators can be avoided with a QBAR switch. It shunts drive current I around the load when any Status Gate input is lost, or when the conductor from the Status Gate output to the QBAR switch input is cut or shorted to ground. Also when power supplies are ramping up or down.

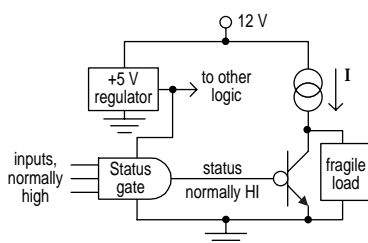

PROTECTS FRAGILE INPUTS ON COLD BOARDS FROM INSERTION INTO HOT SYSTEMS

Boards, peripherals, PCMCIA modules, or subassemblies containing components which can easily be damaged electrically are often overstressed when accidentally inserted into a hot system. Such damage (which may not show up until later) can be prevented by shunting damaging currents around sensitive inputs with a normally-closed QBAR switch.

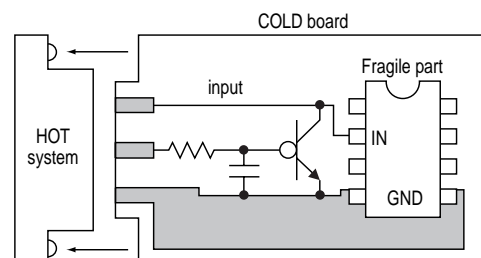

ALARM SYSTEM — QBAR® SWITCH IN SERIES WITH LOAD

A QBAR switch will reliably activate an alarm (a warning display, a cooling fan, a not-ready indicator, or any other load that should be driven during failure) over a wider range of fault conditions than other switch types.

The QBAR switch will turn the alarm on when:

- LO on the status output indicates system failure
- +5 V supply is lost
- status conductor is shorted to ground
- status conductor is cut

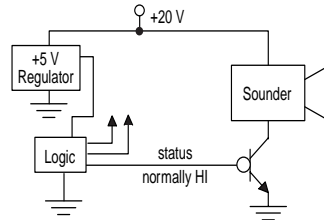

TEMPERATURE CONTROLLED FAN

The temperature controlled fan operates (to prevent overheating) when:

- LO on TC620H output pin indicates over-temperature
- +5 V supply is lost
- control line is shorted to ground
- control line is broken

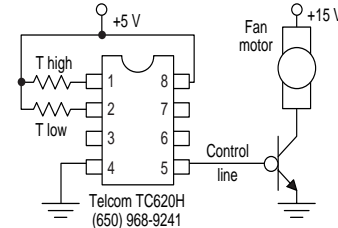

HIGH CURRENT AND VOLTAGE NON-INVERTING DRIVER

Non-inverting driver features unusually low rail-to-rail current loss in HI state.

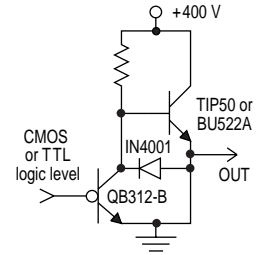

ELECTRONIC CIRCUIT BREAKERS OFFER WIDE ADJUSTMENT RANGE

At low currents, the QBAR switch stays in its normally-closed state. It snaps to open, breaking the circuit when I_{load} is too high for too long. Specifically, when the voltage across the breaker (V_{BR}) applies sufficient voltage via R_{in} for long enough to charge C_{delay} to the QBAR switch's input threshold voltage, the QBAR switch snaps open. These circuit breakers can be reset by cycling the power supply or shorting C_{delay} .

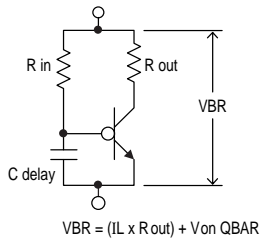

$$V_{BR} = (I_L \times R_{out}) + V_{on\ QBAR}$$

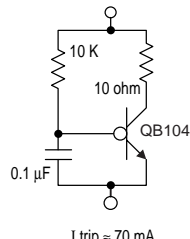

$I_{trip} \approx 70\text{ mA}$
delay $\approx 1\text{ ms}$

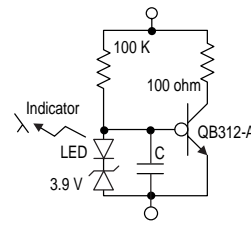

$I_{trip} \approx 15\text{ mA}$
 $C = 0\text{ to }10\ \mu\text{F}$ gives
delay $\approx 50\text{ ms to }1\text{ sec.}$

SLOW-START CIRCUIT

Frequently, full system operation must be inhibited until all supplies are up and other components are functioning properly. Slow-start circuits can both prevent damage to fragile components and help avoid a system's hanging-up in an unsatisfactory state.

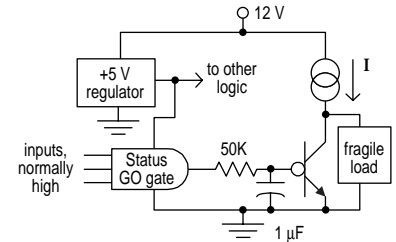

MOTOR DYNAMIC BRAKING

QBAR switches provide motor dynamic braking when power is lost. On power disconnect, and without the QBAR switches, a FET H-Switch will allow the motor to continue spinning freely.

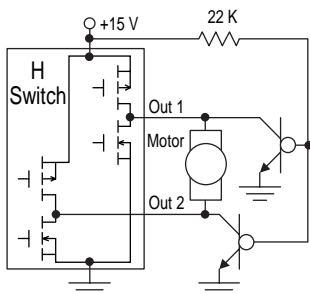

OFF-LINE NOT-READY INDICATOR

QB312 series high voltage QBAR switches can provide indicators and other functions for off-line applications in the US and Europe. Not-ready indicator is ON while logic or other power supply ramps up.

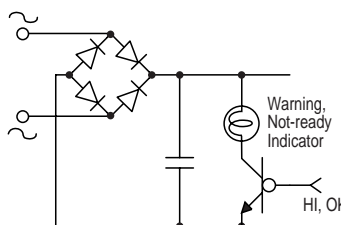

BATTERY SYSTEMS

Unlike all other non-inverting switch ICs, QBAR switches require no connecting wire to the hot battery lead, thus reducing the number of hot lead connections and the consequent hazard from shorts to ground.

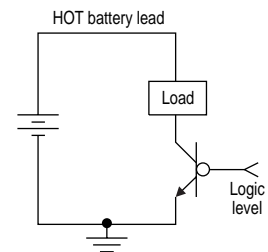

SEQUENCE VOLTAGE REGULATORS

QBAR® switch holds regulator down until sequencing logic HI is received. Could be used, for example, to manage turn-on and turn-off transients of main system supply.

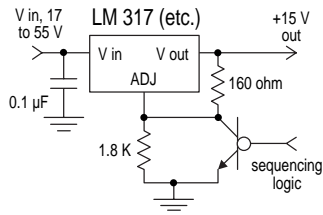

LIMIT CURRENT FOR EXTERNAL PNP/PMOS

Current limiting (or other inhibit features) are provided for op amps and other driver ICs which lack an inhibit pin. The QBAR switch breaks the IC's ground lead when Iload is excessive.

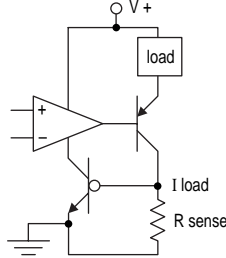

OFF-LINE ALARM

A QBAR switch activates an alarm over a large range of system failure conditions:

- system failure indicated by a LO on the status output
- status conductor cut
- status conductor shorted to ground
- loss of +5 V supply

Any of these conditions will cause the QBAR switch to turn ON, powering the alarm.

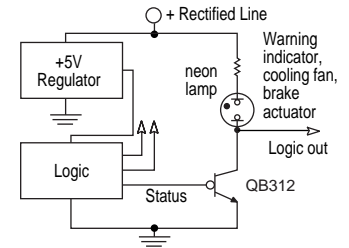

ATTENUATOR/RANGE SWITCH PROTECTS AMPLIFIERS OR OTHER SENSITIVE DEVICES

A QBAR range switch attenuator protects sensitive amplifiers from overdrive damage when the power supply is interrupted or lost.

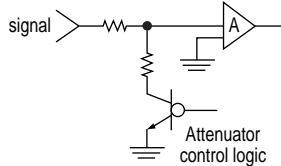

BOOSTER FOR LED DRIVER.

LED (and other similar) drivers with low voltage and/or current capability can drive high brightness displays and other loads simply through non-inverting QBAR switches.

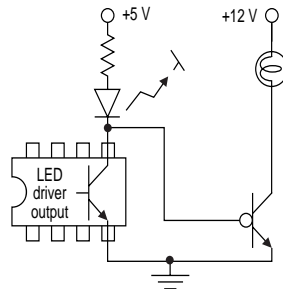

DRIVE PUSH-PULL LOADS SIMPLY

Push-pull loads can be controlled by one signal wire, and without a local logic supply. This Bottom Half H-Bridge provides low-cost remote activation for brushless d.c. motors and other phase/antiphase loads.

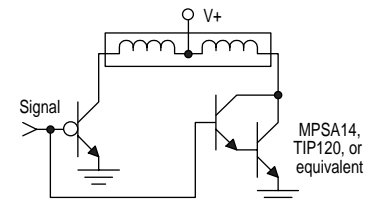

SIMPLIFY INTERFACING

QBAR switches simplify interfacing when system outputs require a non-inverting driver. Easy-to-drive QBAR switches require much less input/control current than electromechanical or opto-electronic (solid-state) relay coils or inputs. QBAR switches also usually operate much faster.

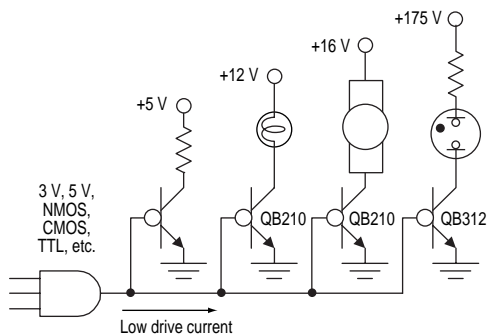

SCHMITT INVERTER HAS LARGE INPUT HYSTERESIS ON LOW SUPPLIES

Inverter (that's right!) provides large and controllable hysteresis.

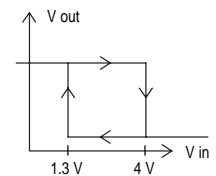
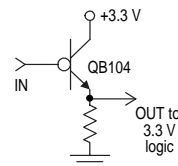

FILTER CAPACITOR DISCHARGERS SAVE ENERGY

Increase your power supply efficiency by using a QBAR[®] switch to lower the parasitic current drain through the bleeder resistor during normal supply operation. Ordinarily, selecting a bleeder resistor is a trade-off between power waste and satisfactory discharge time. A QBAR switch – OFF during normal operation – is turned ON at supply turn-off and stays ON when all voltages fall to zero.

QBAR switch for bleeder in transformer supplies:

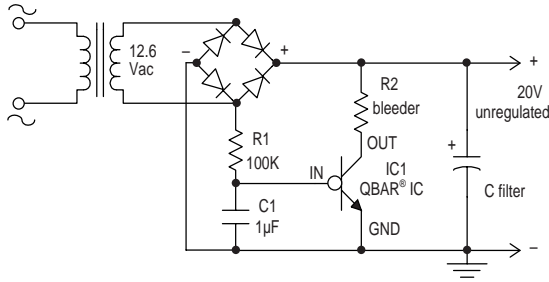

QBAR switch for bleeder in off-line supplies:

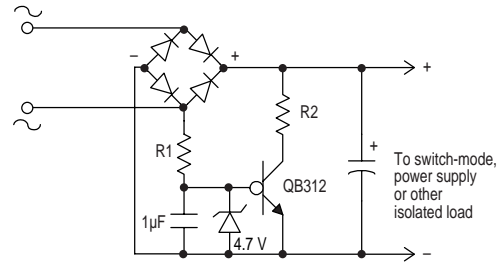

IC1	R2 bleeder
QB210T	10 ohm
QB104Z	150 ohm
QB104M3	150 ohm

a.c. line voltage	R1	R2	QBAR switch
120V (40 V to 132 V)	470 K	1 K	QB312-A
220V (80 V to 264 V)	1 M	4 K	QB312-B

APPLICATIONS HINTS:

Prevent over-voltage damage from inductive kick-back with a signal or rectifier diode,

or a zener diode.

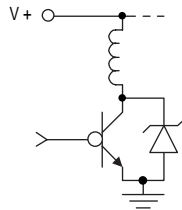
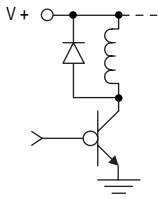

Limit incandescent lamp in-rush current.

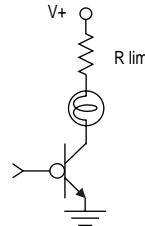

Snubber network reduces interference from load and switch transients.

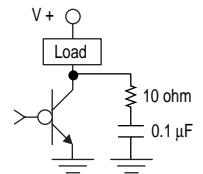

NOTE: When not connected, the Input Terminal floats LOW, putting the QBAR[®] switch in the ON state. Nevertheless, for minimum noise susceptibility, inputs should be connected to valid logic levels.

BitParts Inc.'s products are protected by U.S. patents 5,134,323; 6,259,292; 6,639,777; 6,958,623; foreign patents issued and pending.

BitParts

INC.

BitParts, Inc.
 PO Box 617, Sudbury MA 01776
 Tel: (978) 443-5720 Fax: (978) 443-5744
 bitparts@bitpartsinc.com
 www.bitpartsinc.com

BitParts, Inc. reserves the right to make changes without further notice to these components to improve reliability, function or design. BitParts, Inc. assumes no liability arising from the use of these components. The products of BitParts, Inc. are not intended for use in life support appliances, devices, or systems. Use of a BitParts, Inc. product in such applications without the written consent of the President of BitParts, Inc. is prohibited.

QBAR is a registered trademark of BitParts, Inc.
 © Copyright 2010 BitParts, Inc. All rights reserved.
 Ref: QBAN—02/10